

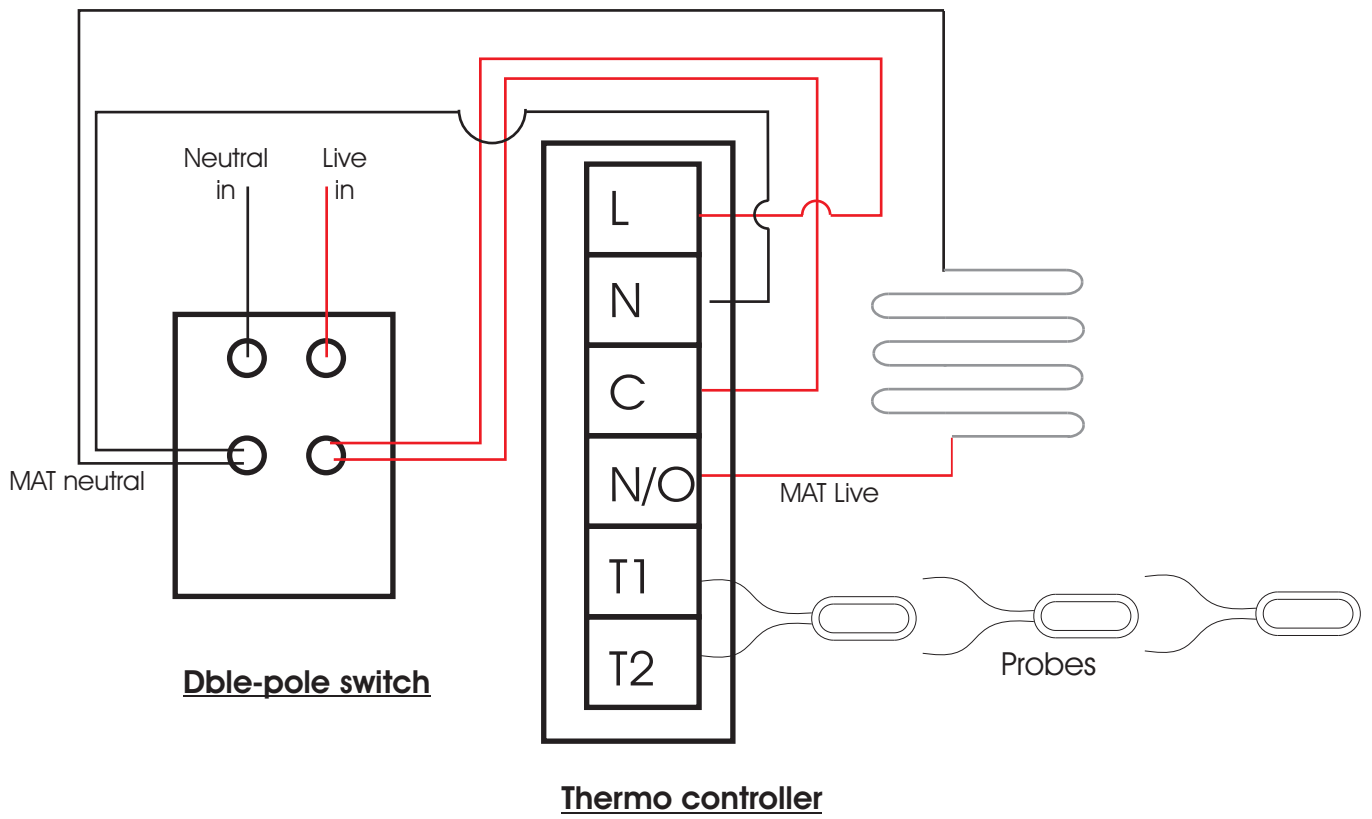

(021) 510 0702 tel 510 0706 fax
082 658 7710 info@lumen8.co.za
Unit 26, Rosbur Park, Neptune St
(cnr Carisle), Paarden Eiland
PO Box 8064, Roggebaai, 8012

WIRING FOR DIGITAL THERMO CONTROLLER



THERMO CONTROLLER

Users Manual V1.2

The Thermo Controller (TC) is designed to give you years of reliable service. In order to correctly operate the unit, and obtain maximum benefit please familiarise yourself with the device before use.

Please note the memory settings marked ***** will be retained with power failures. Those marked **x** will be lost.

FEATURES

- Digital technology gives far more accurate temperature control than traditional bi-metal controllers
- Unlimited temperature sensors can be connected to a single controller and their average temperature will be calculated by the TC
- Controller displays the ambient temperature during operation
- Easy to change the temperature set point (easy user operation)
- Very simple wiring for installers
- Very simple programming for installers
- In-floor sensors can be used to ensure that in-floor temperatures do not exceed a programmable maximum to ensure no damage will occur to wooden or similar type floors
- Ambient temperature readings can be off set by a programmable amount in order to compensate for site anomalies i.e. TC positioned near a heat source.

RATINGS

The TC is rated at 220-250v AC, 16A, 50-60Hz. SABS ratings are pending.

INSTALLATION

This unit must be installed by a qualified electrician. The wiring diagram can be found on the housing cover (Fig 1). All existing electrical wiring safety regulations must be adhered to for normal operation.

LED'S

LED on the right of the display indicates Power ON.

LED on the left of the display indicates Relay ON.

DISPLAY

Under normal operating conditions the TC will display the average ambient temperature as measured by the digital temperature sensors connected to the TC. Only the ambient temperature will be displayed, the temperature measured by in-floor temperature sensors is not displayed.

When the TC is in the "TEMPERATURE SET" or "SETUP" mode the display will flicker.

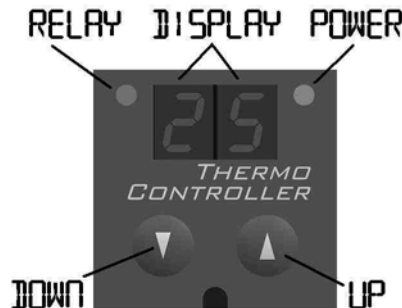

Figure A.

OPERATION

In the default mode the TC measures ambient temperature with its on-board temperature sensor.

In HEATING mode the relay will close and power will be applied to the heater as soon as the ambient temperature measures one degree below the desired (SET) temperature. The relay will open as soon as the ambient temperature measures one degree above the SET temperature.

In COOLING mode the relay operation is reversed.

ADDING ADDITIONAL TEMPERATURE SENSORS

External temperature sensors, placed in the room to measure ambient (AIR) temperature, can be connected to the TC. The TC will then ignore the measurement from the on-board temperature sensor and react to the external temperature sensor or, in the case of several external temperature sensors, calculate and react to the average temperature of these sensors.

In-floor temperature sensors can also be connected to the TC. The TC will then measure the average FLOOR temperature in addition to the air temperature and will not allow the floor to reach a temperature of more than the 'In-floor cut-off temperature'. See MODE 5 / MODE 6 below to set the 'In-floor cut-off temperature'.

MODE 1 and MODE 2 are used to set-up the temperature sensors connected to the TC as measuring AIR or FLOOR temperature (See SETUP below).

To connect external temperature sensors to the TC first make sure the TC is off, then connect all AIR sensors and switch on, and then program the AIR sensors with MODE 1 (See Below). Switch off the TC, disconnected the AIR sensors and connect all FLOOR sensors and switch the TC back on. Program the FLOOR sensors with MODE 2 (See Below). Finally, switched off the TC, and re-connect all the sensors, both AIR and FLOOR. When the TC is switched on again it will recognize the various sensors (knowing which is an AIR sensor, and which is a FLOOR sensor) and incorporate their readings to the correct temperature control function.

TEMPERATURE SET - Setting the desired temperature*

The desired ambient temperature can be set by pressing and holding *either* the "UP" or "DOWN" buttons (see Fig. A) until the display starts flashing. The temperature indicated by the flashing display, is the "SET" temperature. This can be changed by pressing the "UP" or "DOWN" buttons until the desired temperature is displayed. If there is no input for more than 10 seconds the display will stop flashing and change back to displaying the ambient temperature.

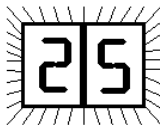

SETUP – Programming the TC

"SETUP" mode is entered by pressing and holding *both* "UP" and "DOWN" buttons until the display changes to "00". As soon as the display changes to "00" the buttons must be released and the display changes to a flashing "00".

The TC is now in "SETUP" mode.

In "SETUP" mode the digit on the left displays one of the 8 possible **MODES** and the digit on the right indicates that particular **MODE's Setting**.

MODE is changed by pressing the "DOWN" button, and **MODE Setting** by pressing the "UP" button.

Both buttons are pressed simultaneously to ENTER settings and EXIT programming. This will execute the selected settings and exit from "SETUP" mode.

Note: If a remote master is used, (see MODE 0 for an explanation of what a master is), it must be connected at all times during the setup operation. The TC will recognize the master and not change its type.

The modes are as follows:

MODE 0 ****FACTORY PRE-SET. DO NOT CHANGE**** *

This mode is used to select a “master” temperature sensor. The TC will not function properly without a “master” selected. The default factory setting for the “master” is the on-board temperature sensor if fitted. A remote master should only be selected if no on-board temperature sensor is present.

To select a master switch off the TC, connect only the temperature sensor that you wish to be set-up as the “master”. In MODE 0 select setting 1.

SETTING – 0 No action
SETTING – 1 Select Master

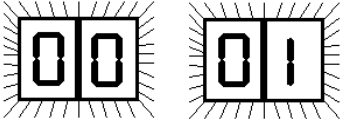

MODE 1 *

Use this mode to set all connected temperature sensors to “AIR”. This means that the temperature sensors connected will be recognised by the TC as measuring air temperature in the future. The TC will recognize the master and not change its type.

SETTING – 0 No action
SETTING – 1 Select Air

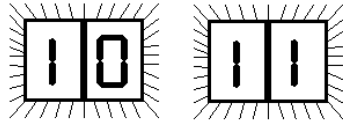

MODE 2 *

Use this mode to set all connected temperature sensors to “FLOOR”. This means that the temperature sensors connected will be recognised by the TC as measuring in-floor temperature in the future. The TC will recognize the master and not change its type.

SETTING – 0 No action
SETTING – 1 Select Floor

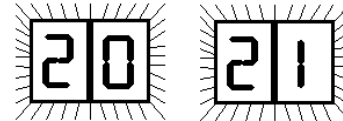

MODE 3 / MODE 4 x

Ambient measured temperature offset.

The temperature displayed by the unit and used for all calculations is calculated by the TC as follows:

DISPLAY TEMP = average MEASURED TEMP – MODE [3] + MODE [4]

The maximum offset therefore is +/- 9 Degrees.

MODE 5 / MODE 6 x

In-Floor cut-off temperature offset.

The in-floor cut-off temperature is calculated as follows:

FLOOR CUT-OFF TEMP = 27 degrees – MODE [5] + MODE [6]

The maximum offset is +/- 9 Degrees (i.e. from 18 to 38 Degrees)

MODE 7 *

Select Cooling or Heating function. Set TC to control a cooling or heating element.

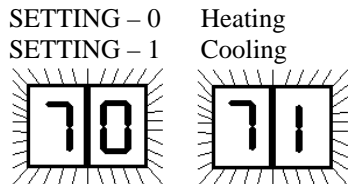

DEFAULT SETTINGS

The default factory setting is as follows:

- On-board Master.
- In-floor cut-off temperature = 27 degrees.
- No ambient temp offset.
- Heating controller.

[*] – Setting will be saved in memory when the power to the unit is switched off.

[x] – Setting will be lost when the power to the unit is switched off.